

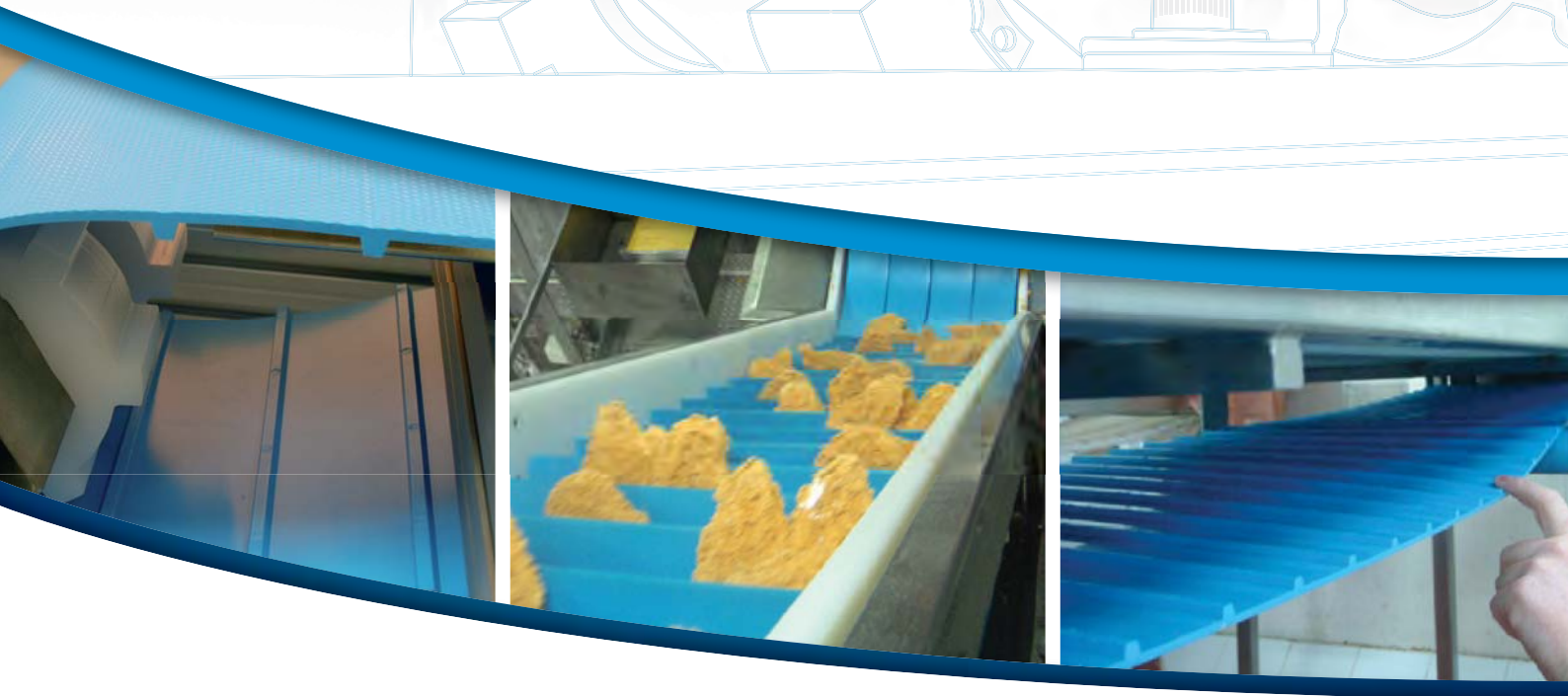

Technical Manual

DualDrive



www.voltabelting.com

VOLTA

The Next Step in Belting

Table of Contents

	Page
1. Introduction.....	3
2. Technical Data.....	4
Volta 'M' Material DualDrive Belts & Fabrication Guidelines.....	4-5
Volta 'M' Material Low Temperature DualDrive Belts & Fabrication Guidelines.....	6-7
Volta 'H' Material DualDrive Belts & Fabrication Guidelines.....	8-9
3. Accessories.....	10
Sprockets, DualDrive Sprocket Types.....	10
Sprocket Spacing.....	10
Sprocket Bore Description.....	11
Securing DualDrive Sprockets : Locking Collars.....	11
Motorized Pulley.....	11
4. Conveyor Construction.....	12
Classic Conveyor Construction.....	12
Conveyor Construction Guidelines.....	12
Tensioning Device.....	13
Return-Ways.....	13
Tight Snub Rollers.....	14
Using Restrictors.....	14
Containment of DualDrive Belts.....	14
"Z" or Swanneck Conveyor Construction.....	15
Centre Drive Conveyor.....	16
Removing Belt for Cleaning.....	16
5. Splicing the DualDrive.....	17
FBW Flat Butt Welding Tool.....	17
FT-Electrode Welding Tool.....	17
6. Volta Fasteners.....	18
DualDrive Lace.....	18
Volta Universal Lace.....	19
7. Belt Calculations.....	20
Pull Force Calculation Procedure.....	20-21
8. Motor Capacity Calculation.....	22
9. Applications.....	23

1. Introduction

DualDrive is a fully extruded positive drive belt featuring a smooth homogeneous character and integral teeth on the drive side.

- ➔ When increased hygiene standards are needed, the DualDrive belt is ideal for replacing existing modular belts
- ➔ DualDrive 'M' material type belt can run on certain types of existing modular sprockets although Volta sprocket design is compatible to all DualDrive belt material types and will ensure longer life and optimal performance. Minimal retrofit is required.

Material Features:

- Smooth homogeneous surface.
- Impression top textures are also available for special non-stick applications.
- No ply or fraying threads.
- Easy and effective cleaning, reducing downtime and water consumption to a minimum.
- No cracks or crevices that can potentially harbor bacteria. The material ensures lower bacteria counts and maximum hygiene.

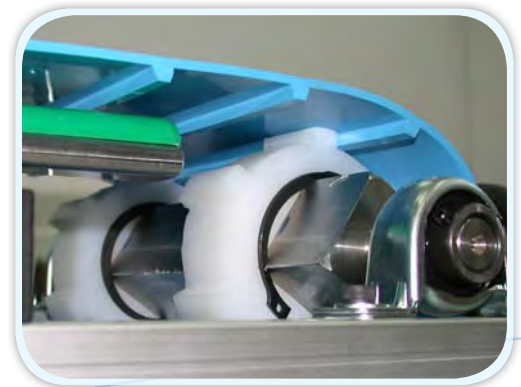

DualDrive positive drive belts lower your water consumption, maintenance and sanitation costs while drastically boosting your production hygiene level.

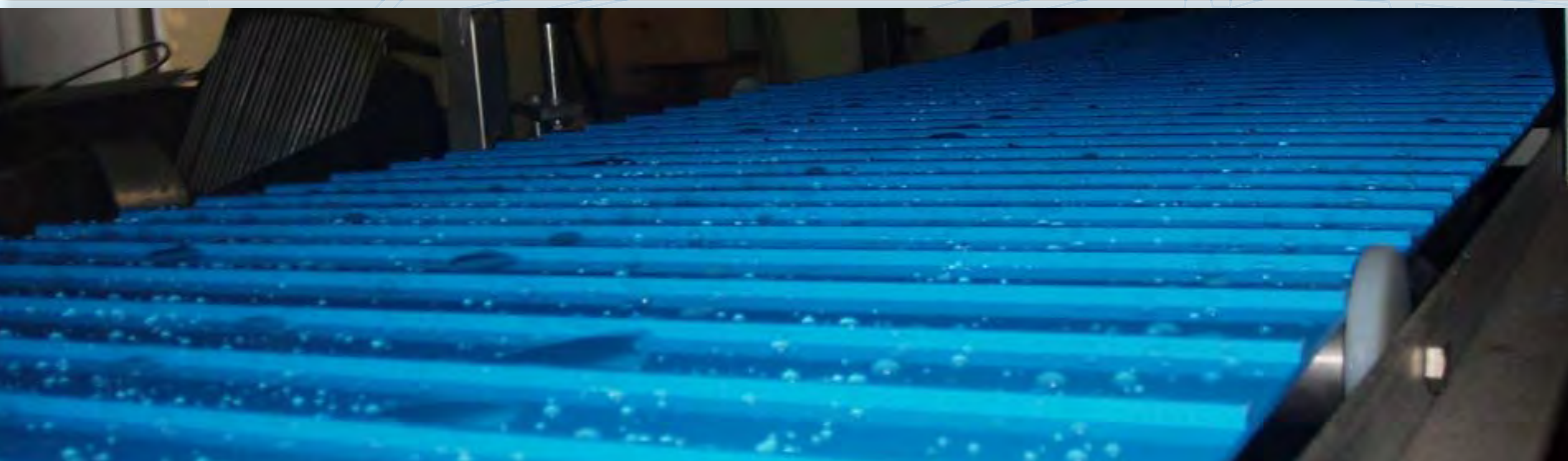

Mechanical Benefits:

- Eliminates modular components that require extensive cleaning and lengthy soaking.
- Greatly reduces noise levels when compared to modular belting.
- Integrated teeth prevent slippage of the belt.
- No belt pretension needed, avoiding elongation and increasing belt life.
- Can also be used as cleats when the teeth are facing up.
- DualDrive Lace allows for ease of belt removal for cleaning or conveyor maintenance.
- Extruded in 30 or 60m (100 or 200 ft.) lengths and 1524mm (60") width.

2. Technical Data

Volta 'M' Material DualDrive Belts

- ➔ **Material:** Volta MW, Beige / Volta MB, Blue
- ➔ **Shore Hardness:** 53D
- ➔ **Temperature Range :** -20° C to 60° C / -5° F to 140° F
- ➔ **Coefficient of Friction:** Steel: 0.5 /Stainless Steel: 0.5 /UHMW: 0.28
- ➔ **Certification:** FDA/ USDA/ USDA Dairy/ EU Approved

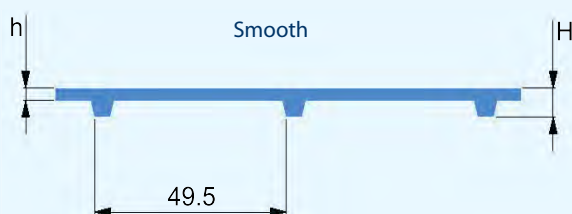
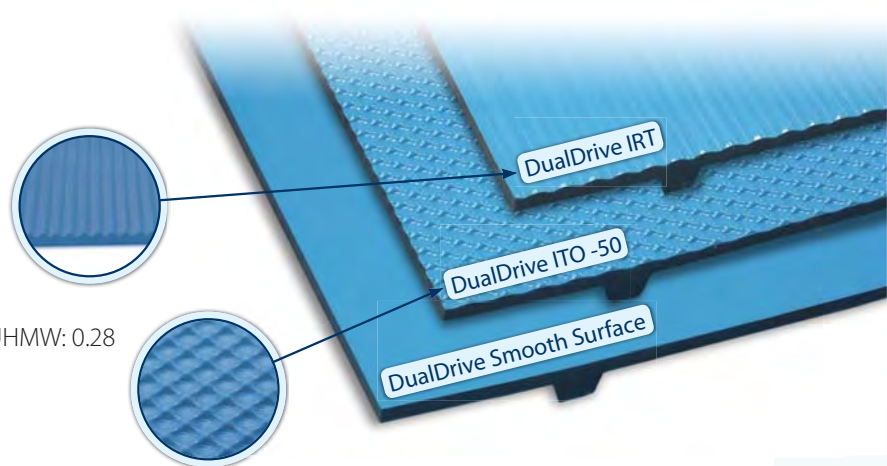

* **h** = Belt Thickness, **H** = Belt Thickness + 4.3mm

Pitch Between Teeth : 49.5mm

Standard Belt Width: 1524mm / 60"

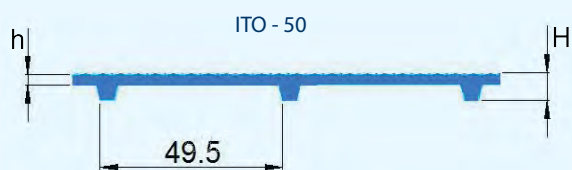

* **h** = Belt Thickness, **H** = Belt Thickness + 4.3mm

Pitch Between Teeth : 49.5mm

Standard Belt Width: 1524mm / 60"

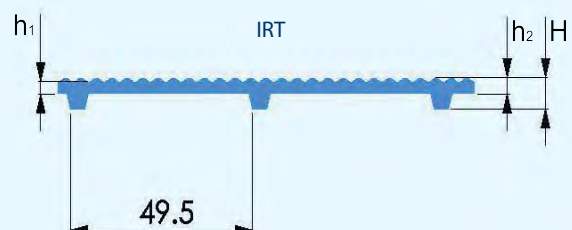

* **h1** = Belt Thickness, **h2** = Belt Thickness + 0.7mm

H = Belt Thickness + 4.3mm

Pitch Between Teeth : 49.5mm

Standard Belt Width: 1524mm / 60"

Table 2.3

Product	FMB-3 DD/ FMW-3 DD	FMB-3 DD ITO - 50	FMB-4 DD	FMB-4 DD IRT
Belt Thickness*	h = 3, H = 7.3	h = 3, H = 7.3	h = 4, H = 8.3	h1 = 3, h2 = 3.7, H = 8
Belt weight (kg/ m ²)	4.5 kg/ m ²	4.2 kg/ m ²	5.7 kg/ m ²	4.6 kg/ m ²
Belt weight (lb/ ft ²)	0.92 lb/ ft ²	0.86 lb/ ft ²	1.16 lb/ ft ²	0.94 lb/ ft ²
Minimum pulley diameter (normal flex)*	80 mm/ 3¼"		120 mm/ 4¾"	100 mm/ 4"
Minimum pulley diameter (back flex)*	100 mm/ 4"		140 mm/ 5½"	120 mm/ 4¾"
Max pull force (kg/ cm width)	6		7.7	6
Max pull force (lb/ in. width)	33.6		43	33.6

Note: This belt can also be driven on existing modular belt sprocket sizes:

- 8 teeth, 5.2" / 132mm
- 10 teeth, 6.5" / 165mm

Pulley Guidelines & Fabrication Options

Table 2.4

Belt Type	FMW-3 DD / FMB-3 DD				FMW-4 DD / FMB-4 DD				
MPD Base Belt	80mm		3¼"		120mm		4¾"		
Minimum Pulley Diameter for V-Cleat									
Electrode	120mm		4.72"		150mm		5.90"		
VLC / VLB 10	130mm		5.12"		170mm		6.70"		
VLC / VLB 13	140mm		5.51"		180mm		7.08"		
VLC / VLB 17	155mm		6.10"		195mm		7.68"		
Minimum Pulley Diameter for Flat Electrode Welded Flights									
Single Electrode 7	125mm		4.92"		150mm		5.90"		
Single Electrode 9	140mm		5.51"		165mm		6.50"		
Double Electrode 7	165mm		6.50"		190mm		7.48"		
Double Electrode 9	NR				NR				
Minimum Pulley Diameter for Flat High Frequency Welded Flights									
App. Temperature	Temp ≥ 0° C / 32° F		Temp < 0° C / 32° F		Temp ≥ 0° C / 32° F		Temp < 0° C / 32° F		
Flight 3 - 5 mm	101mm	3.97"	151mm	5.94"	128mm	5.04"	180mm	7.09"	
Flight 6 - 8 mm	128mm	5.04"	180mm	7.09"	143mm	5.63"	200mm	7.87"	
Minimum Pulley Diameter for Based Sidewalls - Normal Flex									
SW-20	130mm		5.12"		145mm		5.70"		
SW-30	130mm		5.12"		145mm		5.70"		
SW-40	130mm		5.12"		145mm		5.70"		
SW-50	130mm		5.12"		145mm		5.70"		
SW-60	130mm		5.12"		145mm		5.70"		
SW-80	155mm		6.10"		155mm		6.10"		
SW-100	210mm		8.27"		210mm		8.27"		
Minimum Pulley Diameter for Baseless Sidewalls									
		Normal Flex		Back Flex		Normal Flex		Back Flex	
B-SW 30mm/ 1"	1.6mm Thick	80mm	3.15"	110mm	4.33"	120mm	4.72"	140mm	5.51"
B-SW 40 mm/ 1.5"		90mm	3.54"	120mm	4.72"	120mm	4.72"	140mm	5.51"
B-SW 50 mm/ 2"		100mm	3.94"	150mm	5.90"	120mm	4.72"	160mm	6.30"
B-SW 60 mm/ 2.5"		110mm	4.33"	180mm	7.10"	120mm	4.72"	190mm	7.50"
B-SW 80 mm/ 3"		130mm	5.12"	230mm	9.05"	130mm	5.12"	240mm	9.45"
B-SW 100 mm/ 4"		160mm	6.30"	300mm	11.81"	160mm	6.30"	310mm	12.2"
B-SW 130 mm/ 5"	2mm Thick	210mm	8.27"	400mm	15.75"	210mm	8.27"	420mm	16.53"
B-SW 150 mm/ 6"		250mm	9.84"	450mm	17.72"	250mm	9.84"	470mm	18.50"

Note: NR - Not Recommended.

All inch sizes have been converted from metric sizes.

- ➔ **Electrode welded flights:** See the drawing on Page 9. We recommend welding the flights above the exact location of the teeth under the belt. Alternatively, they can be welded in a central position between two teeth but under no circumstances proximate to the teeth. When welding above a tooth, the thickness of the cleat (including the electrode) on top of the belt should not exceed the width of the tooth base under the belt.
- ➔ When choosing the **sprocket size**, it must be equal to or larger than the minimum pulley required.

Technical Data

Volta 'LT' Low Temperature Material DualDrive Belts

- ➔ **Material:** Volta MB LT, Blue
- ➔ **Shore Hardness:** 95A/ 46D
- ➔ **Temperature Range :** -35° C to 35° C / -31° F to 95° F
- ➔ **Coefficient of Friction:** Steel: 0.55 /Stainless Steel: 0.55 /UHMW: 0.30
- ➔ **Certification:** FDA/ USDA/ USDA Dairy/ EU Approved

DualDrive - LT Smooth Surface

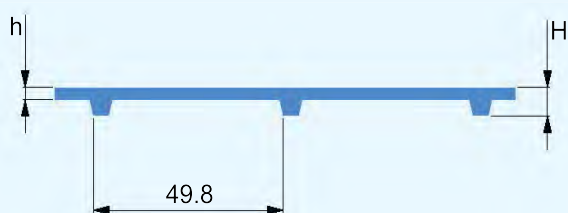

* **h** = Belt Thickness, **H** = Belt Thickness + 4.3mm

Pitch Between Teeth : 49.8 ± 0.4

Standard Belt Width: 1524mm / 60"

Table 2.5

Product	FMB-3 DD LT
Belt Thickness*	h = 3, H = 7.3
Belt weight (kg/ m ²)	4.5 kg/ m ²
Belt weight (lb/ ft ²)	0.92 lb/ ft ²
Minimum pulley diameter (normal flex)*	80 mm/ 3¼"
Minimum pulley diameter (back flex)*	100 mm/ 4"
Max pull force (kg/ cm width)	3
Max pull force (lb/ in. width)	16.8

Important Note: LT belts can only be driven with Volta sprockets.

Pulley Guidelines & Fabrication Options

Table 2.6

Belt Type	FMB-3 DD LT				
MPD Base Belt	80mm		3¼"		
Minimum Pulley Diameter for V-Cleat (working temp. range -20°C to 35°C (-4°F to 95°F))					
Electrode	120mm		4.72"		
VLC / VLB 10	130mm		5.12"		
VLC / VLB 13	140mm		5.51"		
VLC / VLB 17	155mm		6.10"		
Minimum Pulley Diameter for Flat High Frequency Welded Flights					
App. Temperature	Temp ≥ 0° C	Temp ≥ 32° F	Temp < 0° C	Temp < 32° F	
Flight 3 - 5 mm	101mm	3.97"	151mm	5.94"	
Flight 6 - 8 mm	128mm	5.04"	180mm	7.09"	
Minimum Pulley Diameter for Based Sidewalls (working temp. range -20°C to 35°C (-4°F to 95°F))					
SW-20	130mm		5.12"		
SW-30	130mm		5.12"		
SW-40	130mm		5.12"		
SW-50	130mm		5.12"		
SW-60	130mm		5.12"		
SW-80	155mm		6.10"		
SW-100	210mm		8.27"		
Minimum Pulley Diameter for Baseless Sidewalls					
		Normal Flex		Back Flex	
B-SW 30mm/ 1"	1.6mm Thick	80mm	3.15"	110mm	4.33"
B-SW 40 mm/ 1.5"		90mm	3.54"	120mm	4.72"
B-SW 50 mm/ 2"		100mm	3.94"	150mm	5.90"
B-SW 60 mm/ 2.5"		110mm	4.33"	180mm	7.10"
B-SW 80 mm/ 3"		130mm	5.12"	230mm	9.05"
B-SW 100 mm/ 4"		160mm	6.30"	300mm	11.81"
B-SW 130 mm/ 5"	2mm Thick	210mm	8.27"	400mm	15.75"
B-SW 150 mm/ 6"		250mm	9.84"	450mm	17.72"

Note: All inch sizes have been converted from metric sizes.

Guidelines and Suggested Materials for the Fabrication of FMB-3 DD LT belt

- ➔ **Sidewalls:** It is possible to weld Sidewalls from L material to the LT belts.
- ➔ **Flights:** We recommend using using LT material as preferred Flights material. MB material is also acceptable but in this case you should make sure that the temperature of your application does not exceed the regular MB LT materials limit. See the drawing on Page 9. We recommend welding the flights above the exact location of the teeth under the belt. Alternatively, they can be welded in a central position between two teeth but under no circumstances proximate to the teeth. When welding above a tooth, the thickness of the cleat on top of the belt should not exceed the width of the tooth base under the belt.
- ➔ **Electrodes:** We do not recommend using electrodes for welding flights on these belts at all. The entire belt area around the welded electrode becomes rigid and we lose the belt flexibility advantage which characterizes our regular flat belts.
- ➔ **HF Welding:** We only approve HF welding of flights on these LT belts.
- ➔ **Endless Making:** We suggest joining these LT belts with a Butt weld using the FBW Tool.

2. Technical Data

Volta 'H' Material DualDrive Belts

- ➔ **Material:** Volta HW, Beige / Volta HB, Blue
- ➔ **Shore Hardness:** 55D
- ➔ **Temperature Range :** -20° C to 75° C / -5° F to 170° F
- ➔ **Coefficient of Friction:** Steel: 0.4 /Stainless Steel: 0.4 /UHMW: 0.20
- ➔ **Certification:** FDA/ USDA/ USDA Dairy/ EU Approved

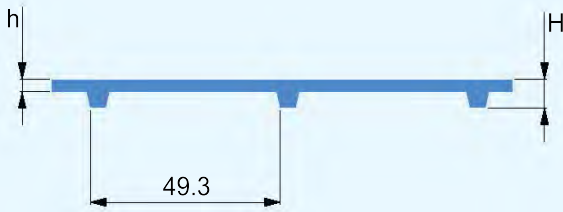

* **h** = Belt Thickness, **H** = Belt Thickness + 4.3mm

Pitch Between Teeth : 49.3mm

Standard Belt Width: 1524mm / 60"

Table 2.1

Product	FHB-3 DD	FHW-3 DD
Belt Thickness*	h = 3, H = 7.3	
Belt weight (kg/ m ²)	4.5 kg/ m ²	
Belt weight (lb/ ft ²)	0.92 lb/ ft ²	
Minimum pulley diameter (normal flex)	100 mm/ 4"	
Minimum pulley diameter (back flex)	150 mm/ 6"	
Max pull force (kg/ cm width)	7	
Max pull force (lb/ in. width)	39.2	

Important Note: H material belts can only be drive with Volta sprockets.

Pulley Guidelines & Fabrication Options

Table 2.2

Belt Type	FHW-3 DD / FHB-3 DD	
MPD Base Belt	100mm	4"
Minimum Pulley Diameter for V-Cleat		
Electrode	132mm	5.20"
VW / VWB 10	157mm	6.18"
VW / VWB 13	177mm	6.97"
VW / VWB 17	217mm	8.54"
Minimum Pulley Diameter for Flat Electrode Welded Flights		
Single Electrode 7	157mm	6.18"
Single Electrode 9	177mm	6.97"
Double Electrode 7	192mm	7.56"
Double Electrode 9	Not Recommended	

- ➔ **Flights:** can be welded on top of a tooth but they must not exceed the width of the tooth or between teeth, but not in the area where sprocket teeth make contact with the belt when driving it.
- ➔ When choosing the **sprocket size**, it must be equal to or larger than the minimum pulley required.

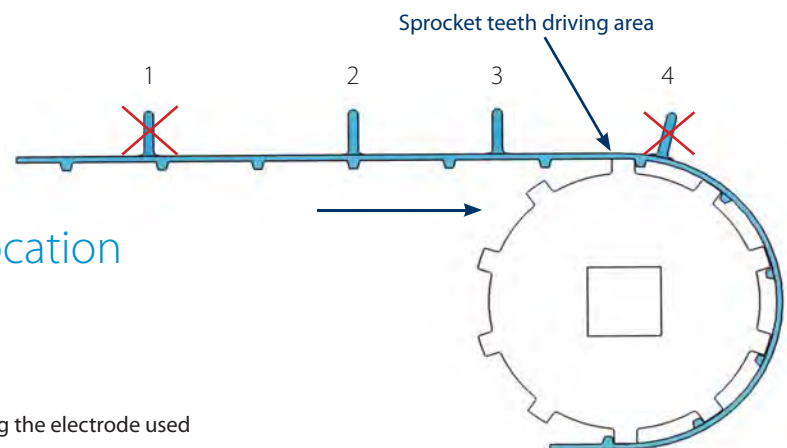

Recommended Cleat Welding Location

* Locations 1 & 4 are not recommended because the cleat is on top of the sprocket teeth driving area.

* Location 2 & 3 are the recommended ones.

Note: In location 2 it is essential that the cleat thickness (including the electrode used to weld it) does not exceed the width of the tooth base under the belt.

3. Accessories

Volta Belting provides all the accessories required to operate the DualDrive belt.

Sprockets

Volta Sprockets are produced using UHMW material which ensures:

- ➔ Durability in high friction applications and long life.
- ➔ Easy Cleaning.

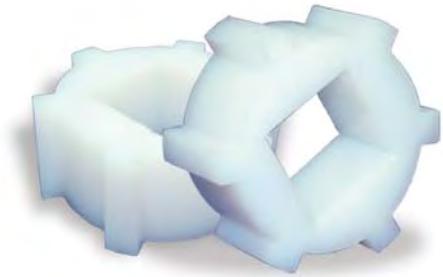

DualDrive Sprocket Types

Number of Teeth	Sprocket Outer Diameter		Sprocket Pitch Diameter			
	3mm & 4mm Thick Belts		3mm Thick Belts		4mm Thick Belts	
	mm	inch	mm	inch	mm	inch
6	93.4	3.67	96.4	3.79	97.4	3.83
8	125.6	4.94	128.6	5.06	129.6	5.10
10	157.7	6.20	160.7	6.32	161.7	6.36
12	189.9	7.47	192.9	7.59	193.9	7.63

- ➔ Standard Drive & Tail Pulley Width = 38⁺¹⁰ mm / 1½^{+3/8}"
- ➔ Standard Square Bore Dimensions = 40mm / 1½"
- ➔ Non-Standard Round Bores are available upon request.

- ➔ Non-Standard Square Bore Dimensions, available upon request:
 - 25mm / 1"; ■ 50mm / 2"; ■ 2½"



Sprocket Spacing

- ➔ Distance between sprocket centers should be between 4" and 6" (100mm to 150mm), according to the belt pull force.
- ➔ If the belt pull force is higher than 50% of the maximum allowed pull force, then the distance between sprockets should not exceed a maximum of 4" (100mm).
- ➔ Make sure that there is no depression of the belt between sprockets.
- ➔ If depression occurs between sprockets, additional sprockets should be fitted.
- ➔ Sprocket location should be in line with conveyor bed strips.

Sprocket Bore Description

The DualDrive sprockets are available in two standard square bore dimensions 1.5" & 40 mm. The 1.5" square bore dimension is also available with round corners. The round corner bore is designed to provide a channel for water to carry debris away during washdown.

Pulley bore dimensions should be chosen according to the load on the shaft to avoid shaft deflection and to transmit the required torque.

Volta supplies other bore dimensions according to your requirements (25 mm, 50 mm, 1", 2" 2.5"). Please contact your local Volta distributor for availability.

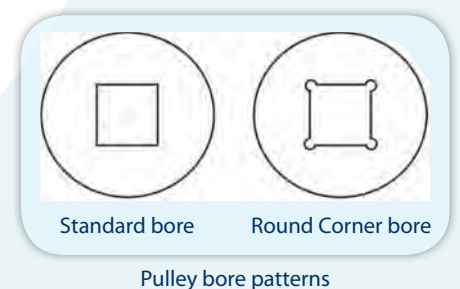

Securing DualDrive Sprockets: Locking Collars

Standard Metal Locking Collar is made of two parts of stainless spring wire that locks with two bolts. Can be assembled without dismantling the shaft. It can be used with all sprocket types and is available in 1½"/40mm.



Square Metal Locking Collar

Square Plastic Locking Collar (UHMW) is made of two plastic parts that locks with two bolts. Can be assembled without dismantling the shaft. It can be used with sprockets that have 10 or more teeth and is available in 1½"/40mm. Can be ordered with round corners for 1½" shaft. Locking Collar face width = 20mm.



Square Plastic (UHMW) Locking Collar

Round Plastic Locking Collar (UHMW) is suitable for 8 teeth sprocket and larger. Dismantling the shaft is required in order to assemble this locking collar. Can be ordered in 1½"/40mm and also with round corners for 1½" shaft. Locking Collar face width = 20mm.



Round Plastic (UHMW) Locking Collar

Additional Options for Securing DualDrive Sprockets

Volta offers three options for those customers who prefer to use a different method of securing the sprockets to the shaft. We recommend checking with your engineering department regarding the effects this will have on your conveyor shafts. Volta does not supply materials for this procedure nor is responsible for damage or weakening of the shaft when using one of these options.

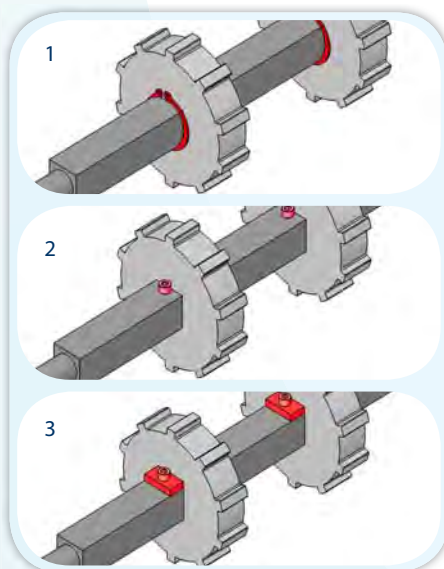

1. Use a "C" ring on the shaft on either end of the sprocket. Cutting a groove suitable for the thickness of the "C" ring you are using is necessary. This method of securing the sprockets is standard with modular belting.
2. Drill and thread a hole at either end of the sprocket. Mount an Allen screw in each hole to secure the sprocket.
3. Mount a small piece of flat metal on either end of the sprocket. Drilling and threading a hole in the shaft and mounting an Allen screw is necessary to secure the metal pieces.

Motorized Pulley

We cooperate with several of the best known motorized pulley manufacturers to develop drum motors fitted with pulleys and teeth suitable to the DualDrive conveyor belt. Please contact your local Volta Belting distributor or your local Motorized Drum supplier for further information.

4. Conveyor Construction

Classic Conveyor Construction

The classic conveyor construction consists of the following parts:

- Volta Drive Sprockets placed on the Drive Side.
- Volta Drive Sprockets or other smooth pulleys placed on the Tail side.
- Slidebed made of UHMW strips.
- Quick Tensioning Device.
- Return Rollers.
- Snub Rollers/Restrictors when needed.
- Many conveyors allow for the quick removal of endlessly welded belts.
- In order to minimize friction we highly recommend using UHMW at all contact points.



If you are required to use stainless steel, please remember that the relative high friction between the two surfaces will affect both performance and tracking of the belt.

Please contact your nearest Volta representative for construction recommendations.

Conveyor Construction Guidelines

When placing the DualDrive Sprocket onto your shaft make sure that all of the sprockets' teeth are arranged in a position matching each other and properly aligned along the shaft.

Note: It is important to support the DualDrive material properly. Many conveyors originally built to run modular have allowed for fewer supports because the modular product is much more laterally rigid and stable. Sufficient support of Dual Drive is essential in order to avoid excessive stretching and wear.

W type 100mm – 150mm / 4" – 6" according to the belt pull force
Up to 50% of the maximum allowed pull force **W** can be 150mm / 6"
Over 50% of the maximum allowed pull force **W** = 100mm / 4"

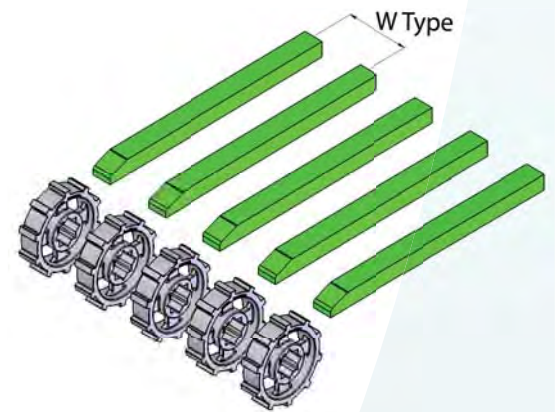

A. half of sprocket outer diameter -4mm (for sprocket diameters refer to page 10).

B. the distance of the front edge of the slide strip from the pulley depends on the cross section of the slide strip and the slide strip supports. B should be kept to a minimum possible distance as long as 'x' is at least 20mm.

C. Distance between Slide Bed Surface and Return Bed Surface at 180° contact engagement between the belt and pulley.

For 3mm belt **C** = Pulley outer diameter + 1mm.

For 4mm belt **C** = Pulley outer diameter.

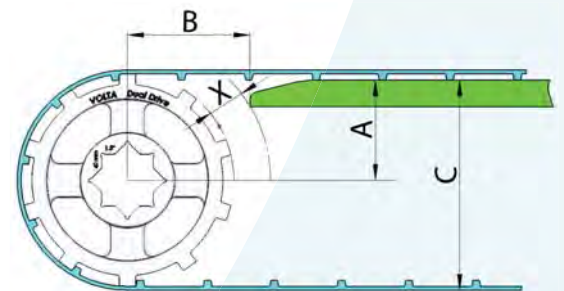

F. between 25mm - 50mm / 1" - 2"

G. Maximum distance between the belt edge and strip : 50mm / 2"

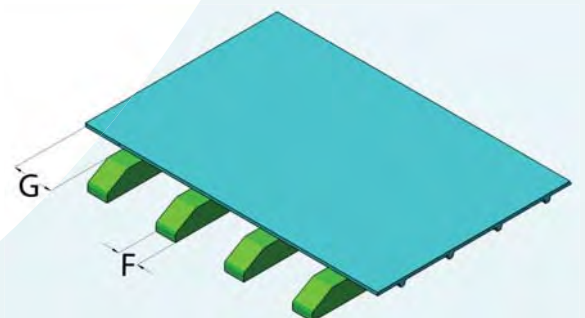

Tensioning Device

Most DualDrive applications require no pretensioning at all. In certain special applications and heavy load applications you may need to tension the belt slightly (up to 0.5%).

The tensioning device has 2 functions on the conveyor. The first is to facilitate the splicing and mounting of the belt and the second is to make cleaning of the belt easier. Opening the quick release tensioning device provides slack between the pulleys, making cleaning of the belt more efficient. Belt tensioning length and structure depends on a number of factors, conveyor length, cleaning method and conveyor structure. Generally a minimum take-up of 5"-8" (130mm – 200mm) is required.

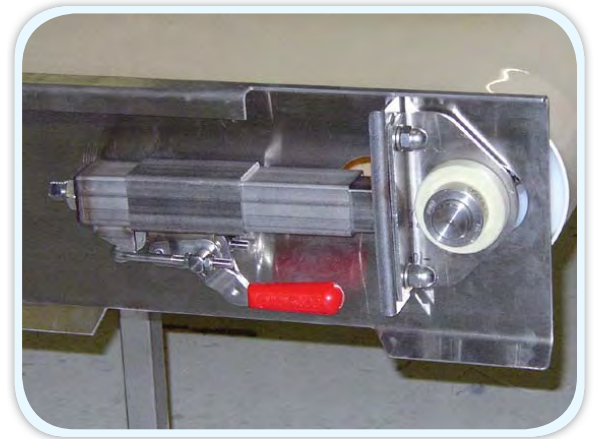

Return-Ways

Return-ways can be created in the form of rollers, continuous rails or shoes. The return-ways should support the belt and enable the proper working of the belt.

- When using continuous rails, the lateral center distance between each rail should not exceed 12" / 305mm and the outer edges should not be indented by more than 2" / 50mm. In order to minimize the friction UHMW material is highly recommended.
- When using rollers the maximum recommended distance between the rollers is 5ft./1.5m. The rollers can be designed with flanges on edges to guide the belt.

Special care should be taken when working with no pretension at all.

➔ Channeling the belt sag by correct spacing of return rollers

The belt can be allowed to sag between the return rollers. However, it is important to avoid slack around the drive sprocket which can cause the belt teeth to disengage from the drive sprocket during operation. The distance between the return rollers should prevent the belt weight from slacking around the drive sprockets. Return support rollers can be engineered to allow for belt accumulation to occur in a specific location.

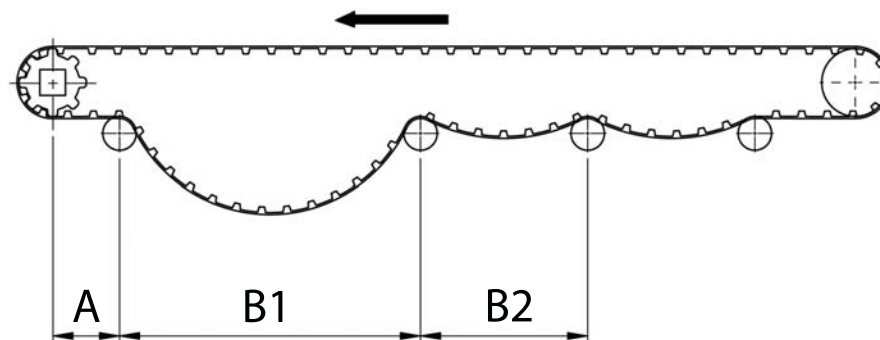

- The space 'B1' is larger than the regular spaces between the return rollers 'B2', in order to use the belt weight to channel the belt sagging into this area and to prevent sagging around the drive pulley.
- The space 'A' is smaller than the regular spaces between the return rollers 'B2'.

➔ Return-ways with flights

If flights are fabricated on the DualDrive material, it is suggested that continuous rails are used. When flights are indented from the belt edge, the return support rails should be positioned to support the belt 1/4"/6mm from the flights. An additional center rail support is recommended for belts 24"/61cm and wider. In order to minimize friction at contact points, UHMW material is highly recommended.

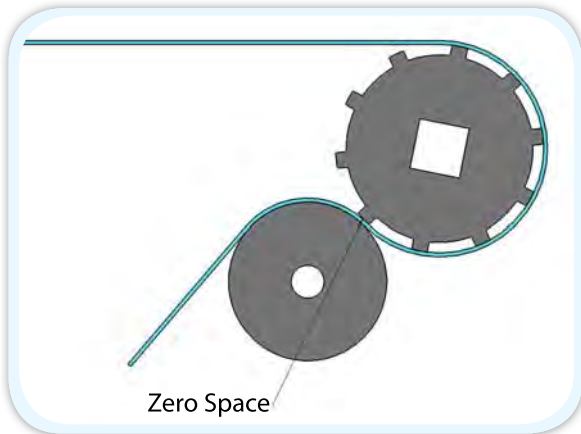

Tight Snub Rollers

In some applications tight snub rollers are used when working without any tensioning at all in order to prevent the disengagement of the belt from the Drive Sprocket. The snub roller is pressed tightly against the drive sprockets preventing the belt from disengaging from the sprocket. In these cases the belt is allowed to sag directly after passing the snub roller and the return rollers can be positioned at equal distances to carry the sag. Safety precautions must be taken to prevent access to this working area.

- Tight Snub Rollers are not suitable when using lace to splice the belt.

Using Restrictors

In some applications restrictors are used when working without any tensioning at all, in order to prevent the disengagement of the belt from the Drive Sprocket. The restrictor is a UHMW block with an arc machined on one side that corresponds to the radius of the sprocket. The restrictor is located close to the sprocket with a small gap allowing for the belt to pass between the sprocket and restrictor and still close enough to prevent the belt from disengaging from sprocket teeth. The restrictor must engage at least 2 sprocket teeth in order to function well. In a typical head drive application, the belt restrictor should be positioned relatively to the head sprockets at 5.30 on the clock (or around 165° of the wrapping arc).

Usually restrictors are placed against each sprocket.

- Restrictors can cause scratches on the belts' upper surface.
- Restrictors are not suitable when using lace to close the belt.

Containment of Dual Drive Belting

Dual Drive belt is not typically tracked like standard flat belting that requires tensioning or steering of the rollers, or like modular style belts where the sprockets' function is to track the belt.

As DualDrive belts run with no pre-tension it is possible to contain the belt rather than track or guide it.

The 2 steps required to achieve containment are:

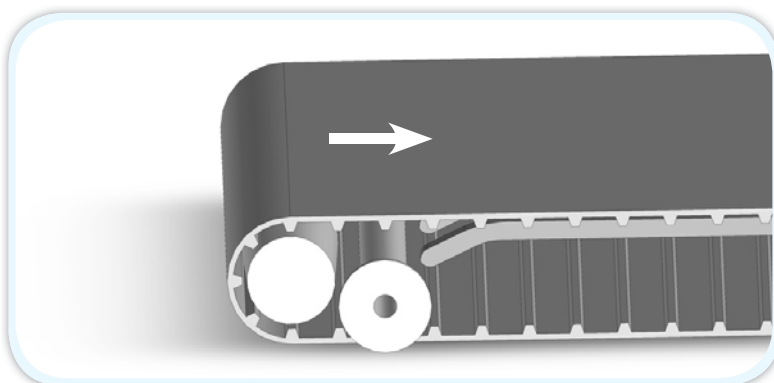

➔ 1. Flanged rollers on the return way.

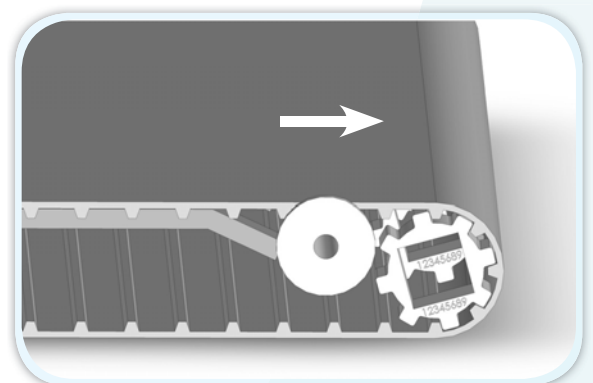

➔ 2. Flanged rollers before the drive side

- ➔ The roller and flanges should be wider than the belt and have clearance of 0.15–0.2" / 4-5mm each side of the belt.

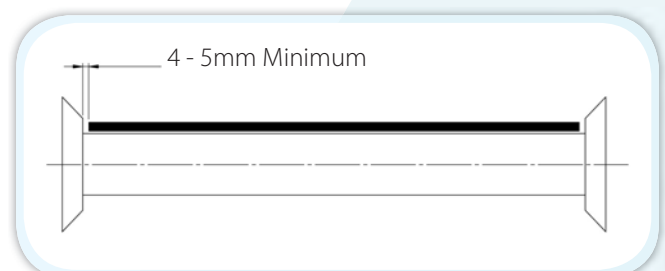

Another option is to use Containment blocks (side shoes) which are used on the frame of the conveyor. In order to minimize friction it is essential to use UHMW in these contact points.

"Z" or Swan-neck Conveyor Construction

The "Z" or Swan-neck conveyor is in relatively common use for lifting the product from a lower to an upper level. DualDrive is ideally suited to this application for several reasons:

- The DualDrive material is relatively stiff all across the belt and will not bend in the middle at the transition from a horizontal to an angled position.
- The DualDrive operates without tension; therefore, the problem of holding the belt in place is reduced and can be achieved easily. The position change (from horizontal to angle) can be made as for regular belts by using a roller or a set of small rollers (see drawing below).

1. Tail Pulley.
2. Roller Set: *Transition Horizontal to Incline.*
3. Incline UHMW Slide Bed.
4. Top Roller: *Transition Incline to Horizontal.*
5. Drive Sprocket.
6. Roller Set: *Return transition horizontal to decline.*
7. Return Support Roller.
8. Bottom Roller: *Return transition decline to horizontal.*
9. Tensioning Device for tail Sprocket.

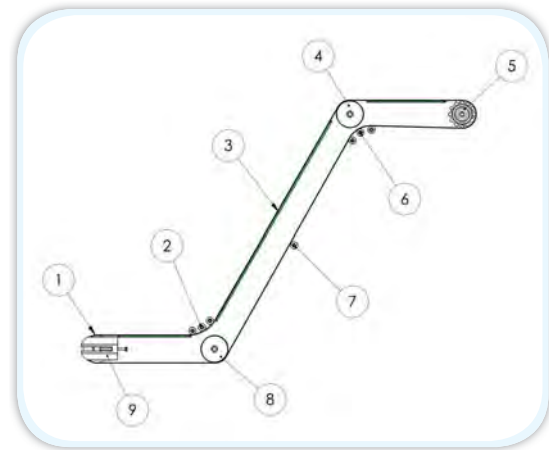

The above drawing demonstrates typical Z-elevator conveyor construction showing the UHMW strip bed. In transition areas 2 + 4 – the belt rubs against the conveyors curved construction which creates a high strain area. Therefore, it is very important to use rollers at these two transition points to minimize the strain and friction at these points.

There are 3 typical options for the transition areas

Shoe- this option is only recommended when using H type belts and they must be made of UHMW.

Roller – one large roller.

Roller sets consisting of 3-4 rollers.

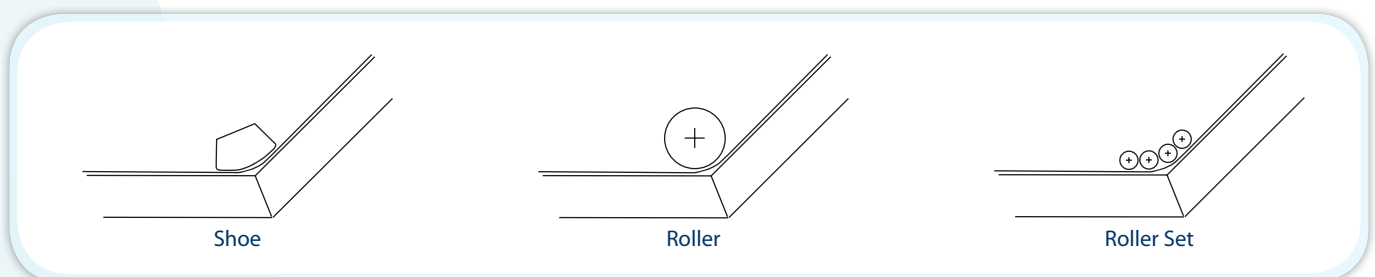

Swan-neck conveyor - transition rollers/ shoe (direction change) options

- The belt curve should be the maximum possible size and not less than the minimum pulley diameter of the belt + fabrications. In principle, the bigger the curve, the better. It is easiest to apply the roller set to larger curves.
- Do not use the shoe option with 'M' material belts, heavy loads or long conveyors. This type is least recommended.
- When using wide belts, it is very important to support the belt on the return side. Using Filghts may cause problems and you may have to make a center gap in the Filght to enable proper belt support.

Center Drive Conveyor

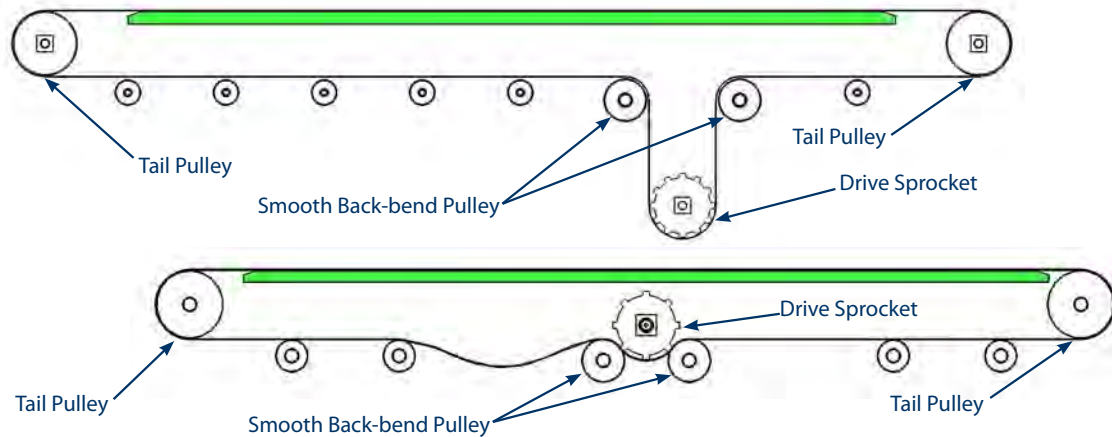

This conveyor is used in two typical applications:

One option is where a larger centre drive pulley is employed and tail pulleys with smaller diameters (N.B. must be larger than the recommended minimum pulley diameter) are required for the transfer of a product, One snub roller is sufficient; it should be positioned tight against the belt running over the drive pulley.

In the upper drawing we can see centre drive application with two smooth back-bending pulleys. In this case, the belt must be tensioned up to 0.5% to prevent slacking and jumping of the belt around the drive sprockets. In many cases the use of tight snub rollers can be seen, as demonstrated in the lower drawing. These snub rollers are positioned tightly against both sides of the pulley to allow bi-directional movement of the belt. In cases where the belt only runs in one direction, one snub roller is used.

Removing the Belt for Cleaning

There are a number of options in the conveyor construction that allow the belt to be removed from the conveyor without being opened. These common features are:

- Quick Release Tensioner - This device permits the release of belt tension without losing belt alignment (Page 13). In some conveyors the telescoping supports are used. During normal operation of the conveyor, the supports are flush with the sides of the conveyor. During cleaning or maintenance, the supports are pulled out and are in a position to hold the conveyor belt during cleaning and maintenance (see drawing).
- The Hinge Lace or Metal Lace can be used to open the belt for cleaning and maintenance (Page 18).

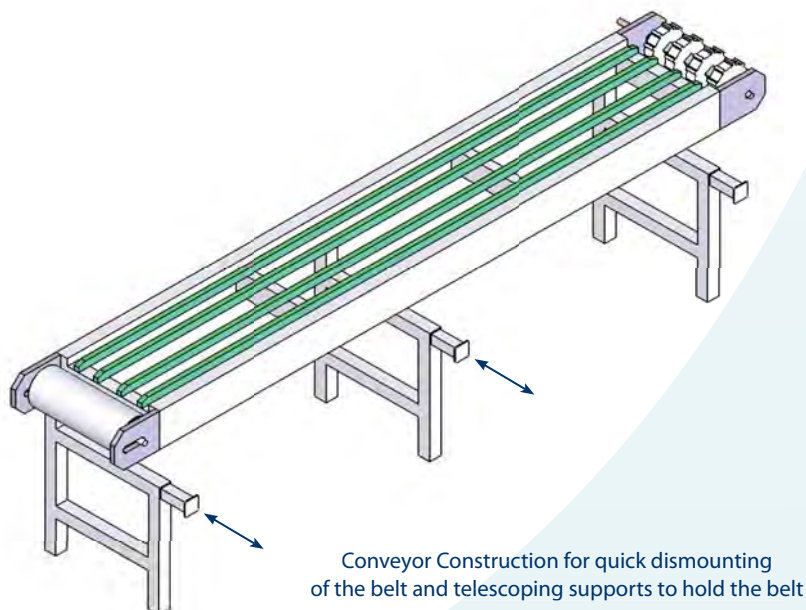

5. Splicing the DualDrive

The DualDrive conveyor belt is manufactured with a series of teeth as an integral part of the belt. These teeth are designed to mesh with the teeth on the DualDrive drive sprockets. To ensure efficient performance, it is necessary to maintain the spacing between the teeth in the region of the weld. We recommend using Volta Tools for this procedure. These tools are designed for use with all of our belts and materials. They are also designed to maintain the correct spacing between the teeth on the DualDrive belt.



FBW Flat Butt Welding Tool

The FBW tool is used to butt weld flat belts making them endless. The process eliminates the use of electrodes making the welding process faster and cleaner.

FBW common model sizes:

FBW-301, FBW-721, FBW-1061 and FBW-1301.



Flat Butt Welding System for Positive Drive Belts

FT - Electrode Welding Kit

The FT-1000 and FT-1500 are designed to provide electrode welding capability for all our Flat belts, including the DualDrive belt. These kits use a trimmer to prepare the belt ends for welding and also for cleaning the joint after welding.

The FT-1000 is capable of welding belts up to 1000 mm (40") wide with a 90° weld.

The FT-1500 can weld belts up to 1500 mm (60") wide with a 90° weld.



Flat Electrode Welding System

6. Volta Fasteners

The Volta Lace is a connector that allows you to easily open the belt by taking the pin out, clean or service the conveyor, reinstall the belt and close the lace with a new pin. Volta belts are renowned for their hygienic and homogeneous characteristics, therefore, they do not require opening and closing on a regular basis- unlike modular belts.

We recommend using lace only when absolutely necessary.

Volta Lace is made of homogeneous food approved materials and is compatible with the Volta 'M' family product belts of 2.5 to 5mm thickness. The thermo-welded join of the lace to the base belt is tough and will not tear apart. Volta lace can also be used in applications where metal detectors are required and we can provide you with a polyester pin upon request.

Volta DualDrive Lace

When using DualDrive Lace, make sure that there are pulleys every 4" (100mm) between the centers of both the conveyor drive and tail shafts. Make sure that the pull force on the belt is less than the allowed pull force of the lace.

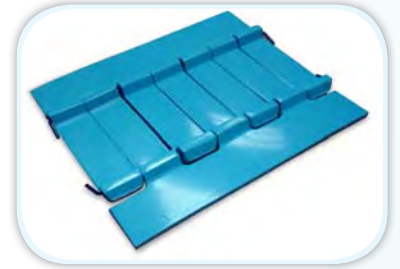

DualDrive Lace Specifications

Product	Volta LMW 16 DD	Volta LMB 16 DD
Description	Flat toothed strip	Flat toothed strip
Material	Volta MW, Beige	Volta MB, Blue
	FDA /USDA /USDA Dairy Approval	FDA /USDA /USDA Dairy Approval
	/ EU Approved	/ EU Approved
Hardness	53D	53D
Working Temp Range	-20°C to 60°C	-20°C to 60°C
	-5°F to 140°F	-5°F to 140°F
Max Pull Force	3.8 kg/cm, 21.3 lb/inch	3.8 kg/cm, 21.3 lb/inch
	When using DD Lace, make sure that the pull force applied on the belt does not exceed the maximum pull force allowed for the lace.	
Minimum Sprocket Diameter	100 mm (4")	
Dimensions	<p style="text-align: center;">DualDrive belt with Lace</p>	
Length	1.2m/ 3.93ft	1.2m/ 3.93ft
Lace Pin	Stainless steel 1.6 - 1.8 mm (0.065")	
	Nylon steel pin 1.65 mm (0.065")	
	(Nylon-coated steel pin)	

Volta Universal Lace

The standard Universal Lace is another option that can be used to fasten DualDrive belts. We recommend using the Universal Lace only when absolutely necessary.



Closing belt with Universal Lace

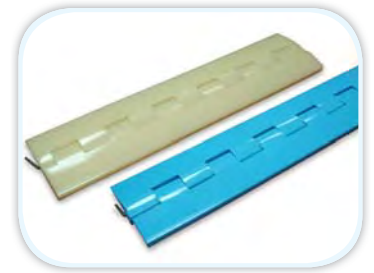

Make sure that the conveyor pulleys fully support the entire face length of the belt or at least 80% of the face length. Note that the maximum allowed pull force for the lace (per cm/inch.) is lower than the allowed pull force of the belt (per cm/inch). Therefore, check that the calculated pull force of your belt is lower than the maximum allowed pull force of the lace.

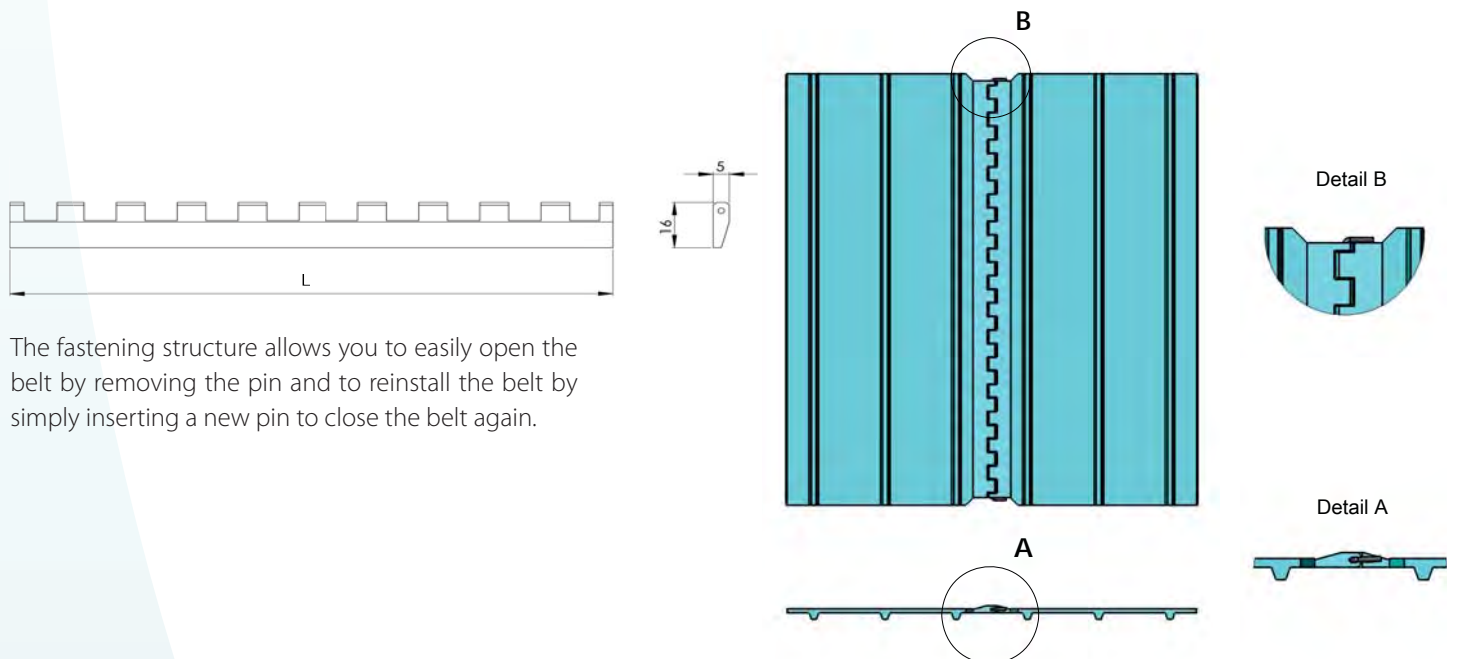

The fastening structure allows you to easily open the belt by removing the pin and to reinstall the belt by simply inserting a new pin to close the belt again.

Universal Lace Specifications

	Volta LMW-U	Volta LMB-U
Description	Flat toothed strip	Flat toothed strip
Material	Volta MW, beige	Volta MB, blue
Hardness	95A	95A
Working Temp Range	-20°C to 60°C/ -5°F to 140°F	-20°C to 60°C/ -5°F to 140°F
Dimensions	5 x 16 mm - 0.2 in x 0.63 in	5 x 16 mm - 0.2 in x 0.63 in
Max Length	3.05 m - 10 ft	3.05 m - 10 ft
Max Pull Force	3 kg/cm - 16.8 lb/in	3 kg/cm - 16.8 lb/in
Minimum Pulley Normal Flex with DD 3mm	80 mm/ 3 1/8 in.	80 mm/ 3 1/8 in.
Minimum Pulley Back Flex with DD 3mm	100 mm/ 4 in.	100 mm/ 4 in.
Hinge Pin	Stainless Steel: 1.2 - 1.4 mm, Polyester: 1.2 mm diameter / FDA approved	

When using lace fasteners, ensure that you keep uniform pitch between teeth so that your conveyor performs well.

7. Belt Calculations

Pull Force Calculation Procedure

1. Net **Pull Force F** on the belt is calculated by the formula

$$F = f_s * (G_1 + G_2) * \frac{X}{L} + f_R * G_2 * \frac{X}{L} + f_R * G_3 + C * G_1 * \frac{H}{L} + 0.25 * G_4$$

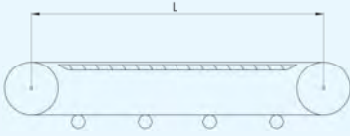
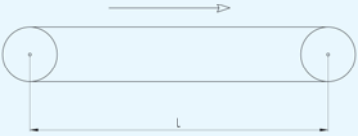
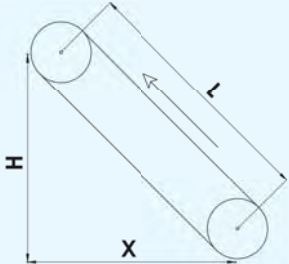
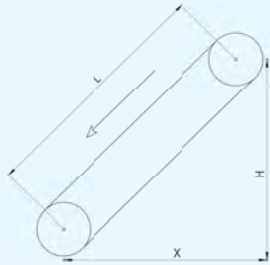
	Conveyor with slide bed 		
Return Bed	Rollers with Bearings $f_R = 0.03$	Rollers with Bushing $f_R = 0.1$	UHMW Sliders $f_R =$ refer to technical data sheet
Slide Bed	$f_s =$ refer to technical data sheet, pgs. 4, 6 and 8		
1. Horizontal transport 	$C = 0; L = X; H = 0$		
2. Incline 	$C = 1$		
3. Decline 	$C = -1$		

Symbols and Dimensions

f_R = Coefficient of friction of rollers (Bearings or Bushing)

f_s = Coefficient of friction of belt on slidebed

L = Conveyor length (m)/ (ft)

H = Elevating height (m)/ (ft)

X = Horizontal distance of conveyor (m)/ (ft)

G_1 = Maximum load on the conveyor (kg)/ (Lb)

G_2 = Belt weight (one direction) (kg)/ (Lb)

G_3 = Weight of supporting rolls-upper and lower section (kg)/(Lb)

G_4 = Maximum accumulated weight (kg)/ (Lb)

* In case of Z Conveyor the calculation is made up of two conveyors, one horizontal and one inclined. In order to find the total Pull Force, add the results of both calculations.

2. Calculate the allowed pull force (Fa) according to number of teeth in mesh

If the number of teeth in mesh is five or less, an adjustment must be made to the max pull force.

Multiply the max pull force by K factor.

Table 5: K factor

Teeth in Mesh	K factor	Comment
6 or more	1	(180° Arc of contact at standard 150 mm/6" pulley)
5	0.8	
4	0.6	(180° Arc of contact at standard 100 mm/4" pulley)

$$F_a = F * K$$

F_a = Allowed Pull Force

3. Choose the belt width

Divide the calculated pull force by the belt width to get the pull force per unit width.

Check that the calculated pull force per unit width is less than the maximum.

Allow Pull Force according to number of teeth in mesh for the belt (Fa).

When using DualDrive Lace, make sure that the Pull force on the belt is less than the allowed Pull force of the Lace.

Example:

An UHMW slide bed conveyor transporting meat packages horizontally.

1. Check if 18" belt (457 mm) is good for this application.

Given

	English-Imperial	Metric
Package weight:	30 (lbs)	13.6 (kg)
Maximum number of packages on belt:	30	30
Conveyor length:	50 (ft)	15.2 (m)
Return rollers weight (bushing):	10 (lbs)	4.5 (kg)
Number of return idlers:	6	6
Pulley diameter:	152 mm	6"
Number of teeth in mesh:	6	6

Procedure

Calculate the Pull Force:

Maximum load:	$G1 = 30 * 30 = 900$ (lbs)	$G1 = 30 * 13.6 = 408$ (kg)
Belt weight - one direction:	$G2 = 0.85 * (18/12) * 50 = 63.75$ lbs	$G2 = 4.15 * 0.457 * 15.2 = 28.82$ kg
Return idler weight:	$G3 = 6 * 10 = 60$ (lbs)	$G3 = 6 * 4.5 = 27$ (kg)
Accumulated weight :	$G4 = 0$	$G4 = 0$
	$F = f_s * (G1 + G2) + f_r * (G2 + G3) + 0.25 * G4$	
	$F = 0.28 * (900 + 63.7) + 0.1 * (63.7 + 60)$	$F = 0.28 * (408 + 28.8) + 0.1 * (28.8 + 27)$
	$F = 282.2$ (lbs)	$F = 127.9$ (kg)

2. Allow Pull Force according to number of teeth in mesh :

For 10 teeth sprockets at 180° Arc of contact - 5 teeth in mesh

$$K = 0.8 \text{ (5 teeth in mesh)}$$

3. Maximum allowed belt load:	$F_a = 0.8 * 33.6 = 26.8$ (lb/in)	$F_a = 0.8 * 6 = 4.8$ (kg/cm)
	$F(\text{max}) = 26.8 * 18 = 482.4$ (lbs)	$F(\text{max}) = 4.8 * 45 = 216$ (kg)
4. Belt width:	18" belt width (45 cm) is ok (the calculated Pull Force is less than the allowed Pull Force)	

8. Motor Capacity Calculation:

Calculation Procedure (for constant speed)

1. Calculation of the required torque for the drive pulley

Metric	English
$M = \frac{F * 9.81 * Dp}{1000 * 2}$	$M = \frac{F * Dp}{12 * 2}$
M = torque [N · m]	M = torque [lb. · ft.]
F = calculated pull force [kg] - see section 6.1, pg. 24	F = calculated pull force [lb.] - see section 6.1, pg. 24
Dp = pulley pitch diameter [mm] - see page 10	Dp = pulley pitch diameter [in.] - see page 10
2. Calculation of drive pulley revolution [rpm]	
$n = \frac{V * 1000}{\pi * Dp}$	$n = \frac{V * 12}{\pi * Dp}$
n = number of drive pulley revolution [rpm]	n = number of drive pulley revolution [rpm]
Dp = pulley pitch diameter [mm] - see page 10	Dp = pulley pitch diameter [in.] - see page 10
V = belt speed [m/min]	V = belt speed [ft./min]
3. Calculation of the motor capacity	
$P = \frac{M * n}{9550 * \eta} * k$	$P = \frac{M * n}{5250 * \eta} * k$
P = power in [Kw] (0.746 Kw = 1 HP)	P = power in [HP] (1 HP = 0.746 Kw)
M = torque [N · m] (from step 1)	M = torque [lb. · ft.] (from step 1)
n = number of drive pulley revolution [rpm] (from step 2)	n = number of drive pulley revolution [rpm] (from step 2)
η = efficiency of the drive transmission equipment ($\eta < 1$)	η = efficiency of the drive transmission equipment ($\eta < 1$)
It depends on the drive type and motor data provided by the manufacturer. In most cases it may vary from 0.6 to 0.85.	
k = correction/ safety coefficient (K > 1)	k = correction/ safety coefficient (K > 1)
Take into account working conditions according to the motor and drive gear data provided by the manufacturer.	
4. Choose a motor: the next size up	

9. Applications

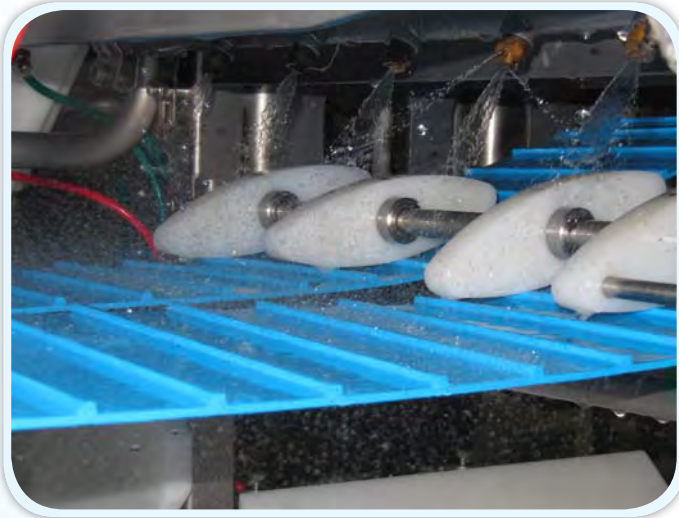

Return Side Support

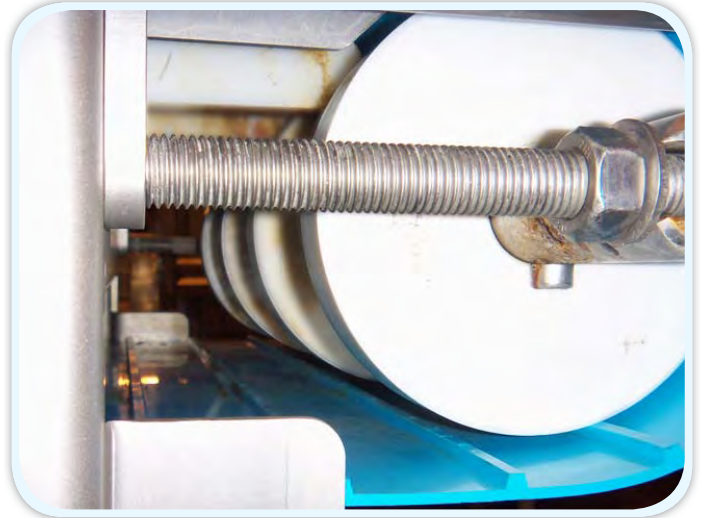

Idler Rollers



DualDrive with Flights



Return Side Support



Volta Drive Sprocket



Modular Drive Sprocket

The DualDrive Solution

- Versatile belt combines high hygienic standards with positive-drive benefits.
- Extremely smooth surface prevents the accumulation of bacteria.
- Positive-drive feature does not require tensioning of the belt.
- Simple heat welded joins and fabrications.
- Huge savings in water and cleaning downtime.
- FDA/USDA AMS Equipment Acceptance Certificate in compliance with NSF/ANSI/3A 14159-3 – 2005 for Meat and Poultry Processing
- USDA Dairy Equipment for selected products.
- Declaration of conformity in compliance with **EU Regulations no. : 10/2011, 1935/2004** and **Directive 2002/72 EC**
- Supports the HACCP concept.



**Corporate Headquarters
Sales and Manufacturing**
sales@voltabelting.com

USA

Tel: +1 973 276 7905
Fax: +1 973 276 7908
Toll Free: 1-877-VOLTAUS

EUROPE

Tel: +31-546-580166
Fax: +31-546-579508

www.voltabelting.com